



LP-F8 Low Profile Self Tapping Female

(page 1 of 2)

	<p>USE WITH:</p> <p>LP-M8A Self Tapping Male</p> 	<p>INSTALL WITH:</p> <p>CT-19 CP-08ST CT-09 CT-10</p>  <p>25Ø Drill</p>
---	---	---

INSTALLATION STEPS

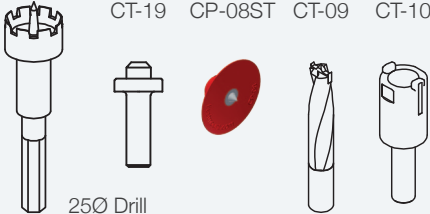
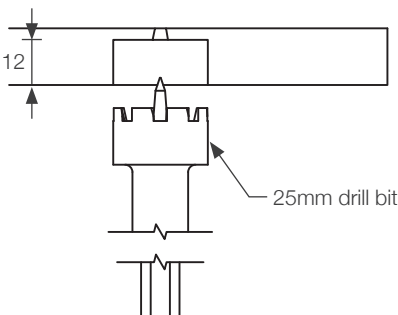
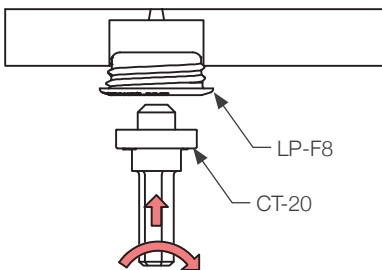
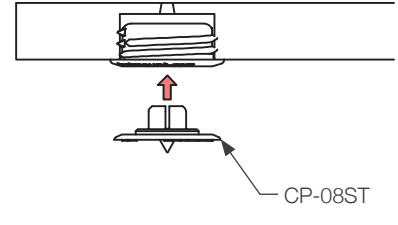
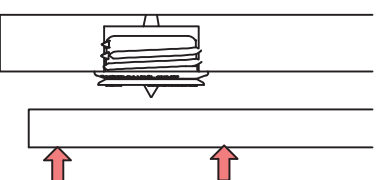
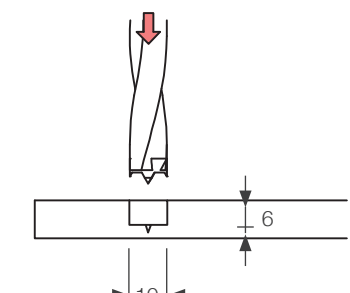
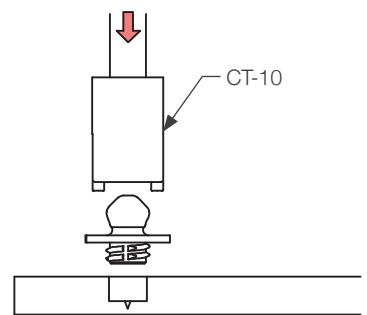
<p>1 Drill 25Ø hole in frame</p> 	<p>2 Screw LP-F8 into frame. Use battery drill with clutch set.</p> 	<p>3 Fit CP-08ST centre point into LP-F8</p> 
<p>4 Press panel onto CP-08ST to mark</p> 	<p>5 Drill panel on mark with CT-09</p> 	<p>6 Screw fit LP-M8A with CT-10. Use battery drill with clutch set.</p> 

A Cutaway view of installed clip

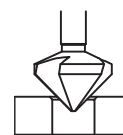
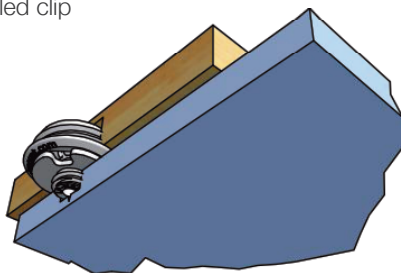

NB. CT-12 to CSK hole edge in hard material (1-2mm)

MORE INFO: Clip Layout Guide TD-02 & TD-08

LP-F8 Low Profile Self Tapping Female

(page 2 of 2)

	<p>USE WITH:</p> <p>LP-M8A Self Tapping Male</p> 	<p>INSTALL WITH:</p>  <p>250 Drill</p>  <p>CT-19</p>
---	---	---

INSTALLATION STEPS Glue On Option

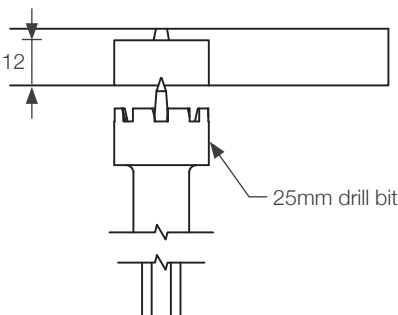
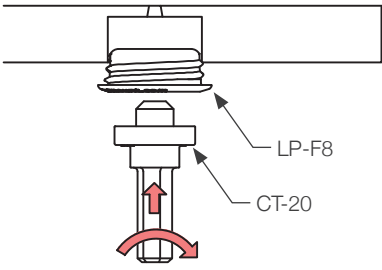
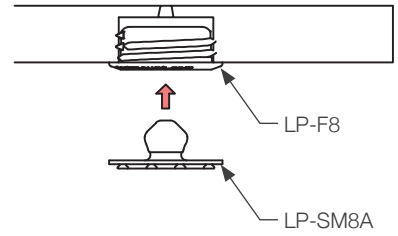
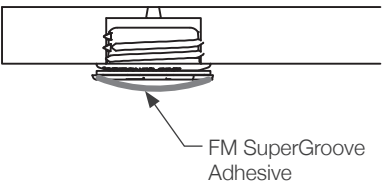
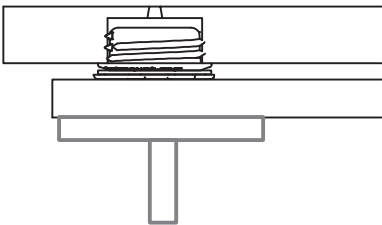
<p>1 Drill 25Ø hole in frame</p>  <p>12</p> <p>25mm drill bit</p>	<p>2 Screw LP-F8 into frame. Use battery drill with clutch set.</p>  <p>LP-F8</p> <p>CT-20</p>	<p>3 Fit LP-SM8A into LP-F8</p>  <p>LP-F8</p> <p>LP-SM8A</p>
<p>4 Apply adhesive to LP-SM8A</p>  <p>FM SuperGroove Adhesive</p>	<p>5 Drill panel on mark with CT-09</p> 	

A Cutaway view of installed clip (panel removed)

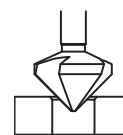
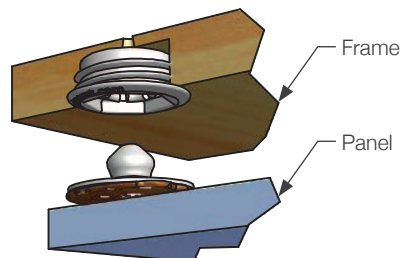

NB. CT-12 to CSK hole edge in hard material (1-2mm)

MORE INFO: Clip Layout Guide TD-02 & TD-08